

TIZiBOT



iR series

GENERAL CATALOG INDUSTRIAL ROBOT

 **IMPLEMENTS**

ADVANTAGE OF USING ROBOTS

LABOR FORCE SECURITY

- Robot can alternate complex operation instead of man.
- Robot operate long-term once installed.
- There is no sudden sick leave or retirement.

PRODUCTS QUALITY UP

- Robot can operate more accurate than man.
- Operation quality will not vary.

PRODUCTIVITY UP

- Robot can handle heavy workpiece which man can't handle.
- Robot can operate faster than man.
- Robot can operate during night and holiday without rest.

COST REDUCTION

- Personnel cost can be reduced by replacing man with robot.
- Process change or system change can be easily done.

VARIOUS APPLICATION OF ROBOTS

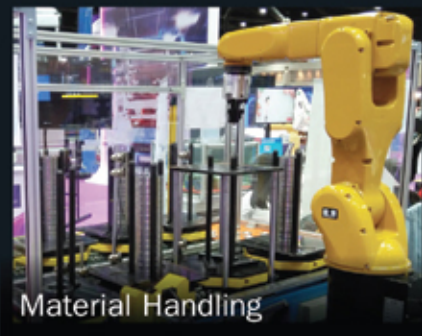

TIZIBOT ROBOT ARMS

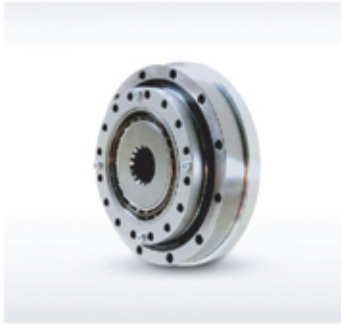

Precision Drive



Small Footprint



Large work envelope



Multiple robot mounting



Electrical and pneumatic near tool flange.



Enclosed arm structure for perform clean application.

COMPREHENSIVE SOFTWARE SOLUTION

OLP & Simulation Software



Offline Programming

Offline Programming has no limits with RoboDK. RoboDK provides a user friendly Graphical User Interface to simulate and program industrial robots. RoboDK will help you avoid singularities and axis limits. Programming experience is not required. More information available in the Offline Programming section of the documentation.

With the RoboDK's API you can also program and simulate robots using Python. Python is a programming language that lets you work faster and integrate your systems more effectively. Python allows expressing concepts in fewer lines of code compared to other languages, making it friendly and easy to learn.

More information available in the RoboDK API section of the documentation. The RoboDK API is also available for C# and Matlab.

Operating Software (TIZIBOT Motion)

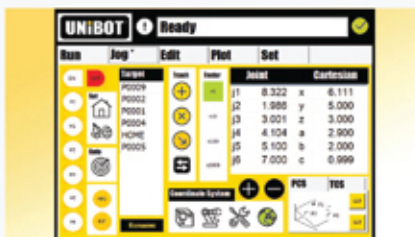

SoftMotion CNC+Robotics SL

CODESYS SoftMotion CNC+Robotics enables the control of coordinated, spatial CNC and robotic motion on qualified CODESYS compatible SoftPLC systems.

Functional principle:

- Project engineering of motion using function library modules
- Configuration of actuated drives with fieldbus support integrated Development System
- Parameterization of axis groups for predefined kinematics in a separate object
 - Decoupling of application creation from the applied hardware by abstracting the drives with drive group names in the device tree
 - Integrated motion planning:
 - with 3D CNC editor according to DIN 66025 (G code) and tabular editor
 - with coordinate values for robot positions in different coordinate systems
- Processing of CNC motion, robotic motion, or other motion tasks in the runtime
- System on the controller with the IEC 61131-3 logic application
- Online editing of CNC programs

TIZIBOT SPECIFICATION

iR18-600

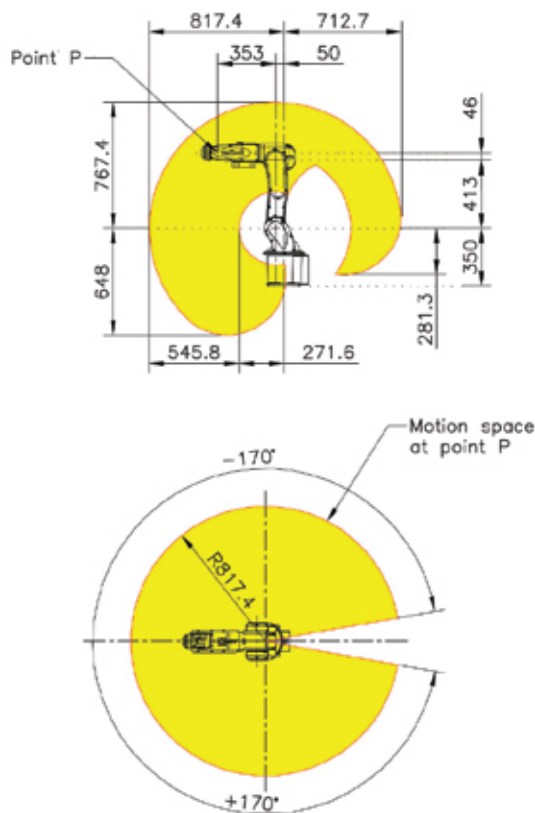

iR18-800

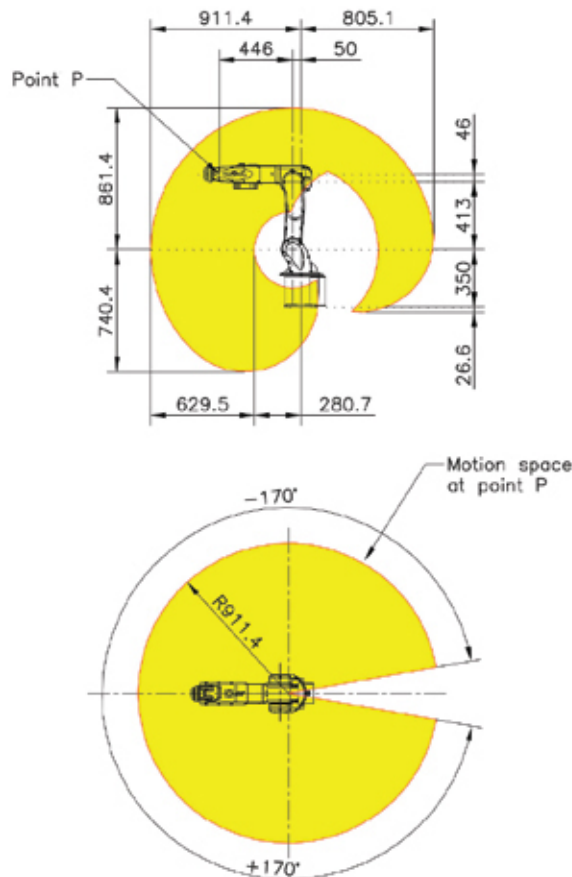

Specification

TIZIBOT

Model	iR18-600	iR18-800
Payload (Kg.)	10	8
Maximum reach radius (mm.)	817	911
Robot Mounting	Any Angle	
Position Repeatability (mm.)	±0.03	
Drive System	AC servo motor	
Position Detection method	Absolute encoder	
Motor speed (r/min.)	3000	
Operating range	J1	±170°
	J2	+135° to -80°
	J3	+155° to -100°
	J4	±190°
	J5	±120°
	J6	±360°
Supply voltage / Current	1Ø , 200-230 V , 50-60 Hz / 20 Amp	

TIZIBOT SPECIFICATION

iR18-1000

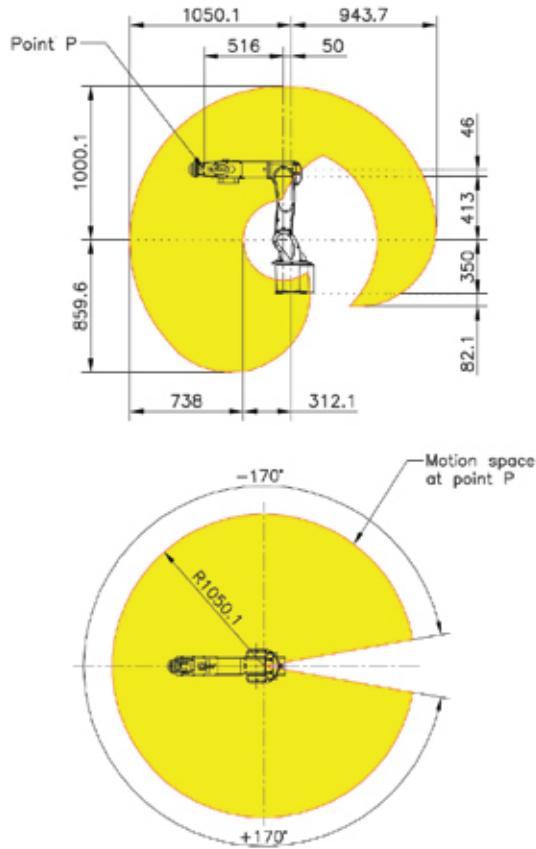

iR18-1200

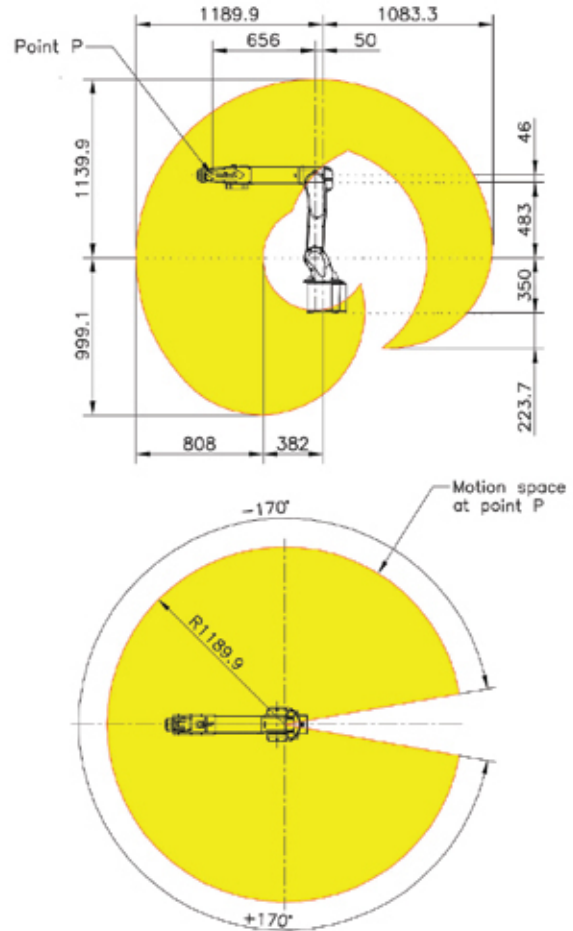

Specification



Model	iR18-1000	iR18-1200
Payload (Kg.)	6	4
Maximum reach radius (mm.)	1050	1190
Robot Mounting	Any Angle	
Position Repeatability (mm.)	±0.03	
Drive System	AC servo motor	
Position Detection method	Absolute encoder	
Motor speed (r/min.)	3000	
Operating range	J1	±170°
	J2	+135° to -80°
	J3	+155° to -100°
	J4	±190°
	J5	±120°
	J6	±360°
Supply voltage / Current	1Ø , 200-230 V , 50-60 Hz / 20 Amp	

Reliability

Quick ROI

Intelligence



Reliability

Quick repair

- Mechanical unit is designed for easy maintenance.
- Diagnostic functions can estimate failure cause.

Inform before failure

- Various diagnostic functions can inform abnormal condition in advance.
- This enables preventive maintenance before failure.

Quick Roi

Installation cost saving

- Replacement of safety devices such as zone switches with DCS (Dual Check Safety) functions can reduce installation costs.
- Replacement of PLC to control peripheral devices with integrated PMC can reduce installation costs

Energy and space saving

- Energy consumption is reduced through a low power design and energy regeneration option.
- DCS (Dual Check Safety) function restricts the robot's work envelope, minimizing floor space requirement.
- Cabinet size becomes smaller. This enables stacking up to three a cabinet and reduces installation space.

Intelligence

Visual Tracking

Through Visual Tracking the robot tracks and picks parts moving on a conveyor by utilizing the vision sensor located upstream. Multiple robots connected via a network can automatically divide the workload among the robots, allowing for automation in various picking and packing processes

Force Sensor/Deburring-Polishing

The six-axis Force Sensor, equipped on the robot's wrist, enables contouring motion of the robot tool while maintaining designate pushing force to the part. The force-controlled robot contributes to automating processes such as deburring of machined part edges and polishing of part surface.

iC 4 Controller

- EtherCAT Platform 
- In put / Out put 16 io
- Field bus
- Dimension
300 mm(W) x 500 mm(L) x 600 mm(H)
- Weight 40 Kg



Teach Pendant

Teach Pendant Model : TP 1.0

Common technical info

- 7" 800 * 480 TFT LCD & Touch
- Emergency switch * 1
- 3 Level enabling switch * 1
- Select switch * 1
- Jog (+,-) key : 12
- Direction key : 4
- Function key : 3
- Function LED : 3
- Status LED : 3

* Option



Remote Pendant

ANCA Motion have designed and manufactured an innovative remote pendant for the modern day control system.

The AMI5000 EtherCAT® Remote Pendant incorporates the latest EtherCAT® fieldbus technology, reducing the overall cable size and weight of the pendant to make it easier to manoeuvre and operate.

AT a glance

- Portable machine control interface
- Compact, lightweight and durable design
- Industry leading EtherCAT® fieldbus
- Customisable button cover
- Machine mounted magnetic cradle
- Operating radius up to 10m

* Option



Operator Box (Control Stations)

IP65 lightweight plastic enclosures for installing switches/pilot lights.

- Lightweight plastic enclosure
- Various mounting options
- Ø22mm switches can be installed
- IP65 degree of protection

* Standard



Daincube Teach Pendant Model : DTP-W7

Common technical info

- 7" 800 * 480 TFT LCD & Touch
- Emergency switch * 1
- 3 Level enabling switch * 1
- Select switch * 1
- Jog (+,-) key : 12
- Direction key : 4
- Function key : 3
- Function LED : 3
- Status LED : 3

* Option



LNC Pendant

LNC Pendant Model : RF8800D3

- Handheld touch-screen
- Digital multiaxial control(Maximum 9 axis)
- Handheld touch-screen and 1.2 meter Anti-shock design
- IP65 waterproof and dustproof level
- Built-in MPG makes operation easier.
- Dedicated operation panel for track teaching.
- Space arc function
- Instrument and workpiece transpose function

* Option



tiz@tiz.pl
(+48 22) 423-33-14
(+48 22) 423-33-15



www.tizimplements.eu